

# Captive Screw Type 1 5/16-18 Thread

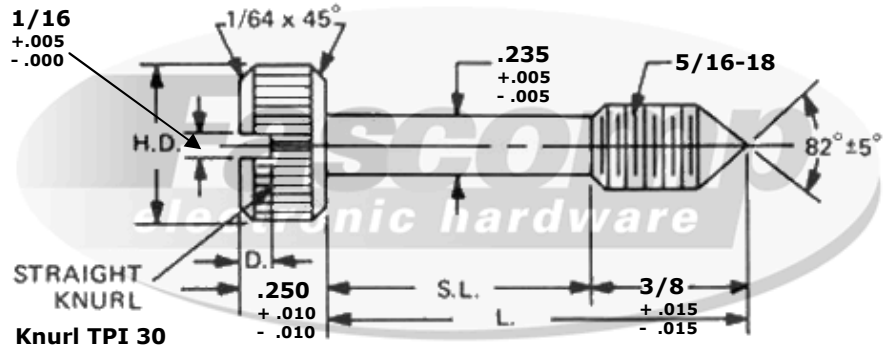

| Captive Screws - 15/16-18 Thread |            |                        |                        |                      |  |
|----------------------------------|------------|------------------------|------------------------|----------------------|--|
| FCXXXX                           | Length (L) | H.D.<br>+.015<br>-.000 | S.L.<br>+.010<br>-.010 | D.<br>+.010<br>-.000 |  |
| FC0299                           | 1          | 9/16                   | 5/8                    | 3/32                 |  |
| FC0300                           | 1-1/16     | 9/16                   | 11/16                  | 3/32                 |  |
| FC0301                           | 1-1/8      | 9/16                   | 3/4                    | 3/32                 |  |
| FC0302                           | 1-3/16     | 9/16                   | 13/16                  | 3/32                 |  |
| FC0303                           | 1-1/4      | 9/16                   | 7/8                    | 3/32                 |  |
| FC0304                           | 1-5/16     | 9/16                   | 15/16                  | 3/32                 |  |
| FC0305                           | 1-3/8      | 9/16                   | 1                      | 3/32                 |  |
| FC0306                           | 1-7/16     | 9/16                   | 1-1/16                 | 3/32                 |  |
| FC0307                           | 1-1/2      | 9/16                   | 1-1/8                  | 3/32                 |  |
| FC0308                           | 1-9/16     | 9/16                   | 1-3/16                 | 3/32                 |  |
| FC0309                           | 1-5/8      | 9/16                   | 1-1/4                  | 3/32                 |  |
| FC0310                           | 1-11/16    | 9/16                   | 1-5/16                 | 3/32                 |  |
| FC0311                           | 1-3/4      | 9/16                   | 1-3/8                  | 3/32                 |  |
| FC0312                           | 1-13/16    | 9/16                   | 1-7/16                 | 3/32                 |  |
| FC0313                           | 1-7/8      | 9/16                   | 1-1/2                  | 3/32                 |  |
| FC0314                           | 1-15/16    | 9/16                   | 1-9/16                 | 3/32                 |  |
| FC0315                           | 2          | 9/16                   | 1-5/8                  | 3/32                 |  |
| FC0316                           | 1          | 3/4                    | 5/8                    | 1/8                  |  |
| FC0317                           | 1-1/16     | 3/4                    | 11/16                  | 1/8                  |  |
| FC0318                           | 1-1/8      | 3/4                    | 3/4                    | 1/8                  |  |
| FC0319                           | 1-3/16     | 3/4                    | 13/16                  | 1/8                  |  |
| FC0320                           | 1-1/4      | 3/4                    | 7/8                    | 1/8                  |  |
| FC0321                           | 1-5/16     | 3/4                    | 15/16                  | 1/8                  |  |
| FC0322                           | 1-3/8      | 3/4                    | 1                      | 1/8                  |  |
| FC0323                           | 1-7/16     | 3/4                    | 1-1/16                 | 1/8                  |  |
| FC0324                           | 1-1/2      | 3/4                    | 1-1/8                  | 1/8                  |  |
| FC0325                           | 1-9/16     | 3/4                    | 1-3/16                 | 1/8                  |  |
| FC0326                           | 1-5/8      | 3/4                    | 1-1/4                  | 1/8                  |  |
| FC0327                           | 1-11/16    | 3/4                    | 1-5/16                 | 1/8                  |  |
| FC0328                           | 1-3/4      | 3/4                    | 1-3/8                  | 1/8                  |  |
| FC0329                           | 1-13/16    | 3/4                    | 1-7/16                 | 1/8                  |  |
| FC0330                           | 1-7/8      | 3/4                    | 1-1/2                  | 1/8                  |  |
| FC0331                           | 1-15/16    | 3/4                    | 1-9/16                 | 1/8                  |  |
| FC0332                           | 2          | 3/4                    | 1-5/8                  | 1/8                  |  |

Create a part number:

| Length                | Material | Finish |
|-----------------------|----------|--------|
| FCXXXX                | XX       | XX     |
| _____ - _____ - _____ |          |        |

Source Control Drawing:  
To be produced by  
Fascomp Electronic Hardware

| Material           |                 |
|--------------------|-----------------|
| Material Code (XX) |                 |
| B                  | Brass           |
| S                  | Steel           |
| SS                 | Stainless Steel |

| Compatible Finish (XX) |                                       |
|------------------------|---------------------------------------|
| B, S, SS               | 0 - Plain                             |
| B, S                   | 5 - Nickel Plate (QQ-N-290)           |
| B, S                   | 12 - Zinc Clear (ASTM-B-633)          |
| B, S                   | 16 - Electro Tin (MIL-T-10727 TYPE 1) |
| SS                     | 20 - Passivation (MIL-F-14072D)       |
| B, S, SS               | 26 - Black Oxide                      |
| B, S                   | 28 - Zinc Yellow (ASTM-B-633)         |

**Tolerances**  
Unless otherwise Specified  
.xxx +/- .005  
.xx +/- .010  
Angular +/- 1 Degree  
Linear +/- .005  
**Break all sharp edges**



This document is the property of Fascomp Inc. and shall not be reproduced, distributed, or used as a basis for manufacturing without written permission from Fascomp Inc.